

Thermostatic Valve



FEATURES

- FLOW RATES OF 1500-2800 USGPM
- TAMPER-PROOF TEMPERATURE SETTINGS OF 80°F - 230°F
- COMPLETELY SELF-CONTAINED
- POSITIVE 3-WAY VALVE ACTION
- AVAILABLE IN CAST IRON, STEEL, DUCTILE IRON, AND BRONZE
- 8" FLANGED

APPLICATIONS

- ENGINE & COMPRESSOR COOLING SYSTEM
- LUBE OIL SYSTEMS
- COGENERATION HEAT RECOVERY LOOPS
- PROCESS CONTROL
- TEMPERATURE MIXING OR DIVERTING

AMOT Model D Thermostatic Valves are fully automatic, 3-way fluid temperature controllers for diverting applications. They are used to provide reliable control lubrication oil cooling systems. These valves are suitable for process control and industrial applications where fluids must be diverted depending on their temperatures. They may also be applied to cogeneration systems to control temperatures in the heat recovery loop assuring proper engine cooling and maximizing heat recovery.

TAMPER-PROOF

As with other AMOT thermostatic valves, Model D utilizes fully enclosed, factory-set temperature element assemblies which provide tamper-proof operation. To change a valve setting it is necessary to exchange the temperature elements.

MANUAL OVERRIDE

A Manual Override is standard on these valves and allows the operator to force all the fluid through the cooler.

HIGH RESISTANCE TO SHOCK

AMOT Thermostatic Valves display excellent reliability even under extreme shocks or vibration and some model have been qualified to MIL-S-901 and MIL-V-19772.

OPERATION

The valve is supplied with the temperature element assemblies factory-set to the nominal temperature setting. Temperature is sensed at Port A which remains open to Port B (bypass) until the fluid temperature reaches a point 8 - 10°F below the nominal setting. As the temperature continues to rise, the sliding valve moves to close off Port B and open Port C (connected to the cooler or heat exchanger.) Port B is fully closed 8 - 10°F above the nominal setting. The valve continually modulates the fluid flow to maintain the nominal temperature. For optimum control, the system should be sized so about 1/2 the total fluid flow is passing through the cooler at full load.

For long life, AMOT Model D valves should not be exposed to continuous temperatures exceeding 40°F above their nominal temperature setting. For occasional short periods (1/2 hour or less), they can be exposed to temperatures of 60°F above their nominal temperature setting.

To operate the Manual Override and force all of the fluid to flow through the cooler, remove Cap (33) and loosen Locknut (34). Turn the shaft counterclockwise to its limit. To return the valve to its automatic mode, turn the shaft clockwise to its limit. Tighten the Locknut and replace the Cap.

PIPING DIAGRAM

FOR DIVERTING APPLICATIONS

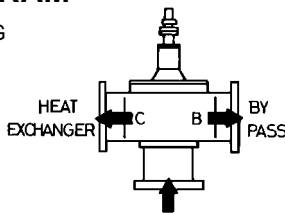

CONTROLLED TEMPERATURE INLET

DIMENSIONS

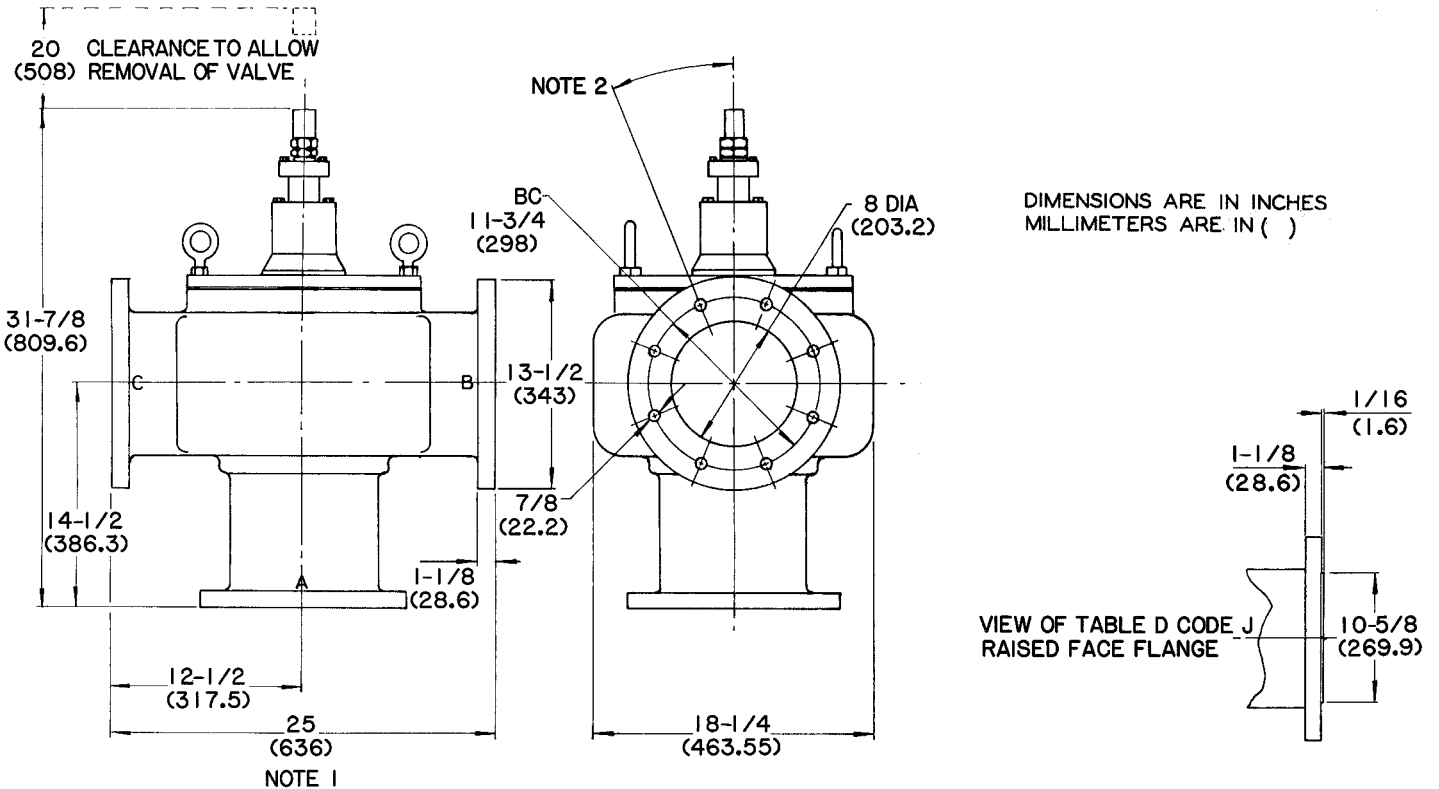

NOTE 1: DIMENSION INCLUDES FLANGE RAISED FACES ON TABLE D CODE J FLANGE.

NOTE 2: BOLT HOLES STRADDLE CENTERLINES OF ALL AXES

SPECIFICATIONS

Internal Trim Materials Stainless Steel & Bronze
Standard Seal Material..... Buna N
Max. Allowable Pressure Drop Across Valve .. 20 psi (140 kPa)

Valve Pressure Rating
8DOCF, 8DODF 150 psi (1034 kPa)
8DOSJ 230 psi (1585 kPa)

Net Weight
8DOCF, 8DODF 550 lbs (250 kg)
8DOSJ 575 lbs (260 kg)

INSTALLATION

AMOT Model D Thermostatic Valves should be installed in the vertical position if possible to allow the use of mechanical lifting devices when removing the element assembly (approximately 125 lbs.). The valve may also be installed upside-down if required. In all cases, it is imperative that an adequate vent line (1/2" minimum) be used to prevent air binding.

Since the valve weighs about 500 pounds, provision must be made for its proper support in the system. It must not be used to support long and heavy lengths of pipe nor used to draw up lengths of pipe which have been fabricated too short since flange breakage may result.

For piping diagrams regarding specific applications, refer to Form 913, AMOT Thermostatic Valves General Information. Model D Valves are designed for diverting applications and may not provide adequate temperature control if used as mixing valves.

SELECTIONS

AMOT Thermostatic Valves are selected by the anticipated flow rate through the valve. Refer to Fig. 1. Pressure drop across the valve is usually limited to approximately 2 psi to 7 psi to maintain good temperature regulation.

Versions available from USA factory:

Cast Iron	Steel	Ductile Iron	Bronze
8DOCF	8DOSJ	8DODF	8DOBF

Models 8DOCF, 8DODF, and 8DOBF have ANSI 125 lb. Class compatible flat face flanges.

Model 8DOSJ has ANSI 150 lb. Class compatible raised face flanges.

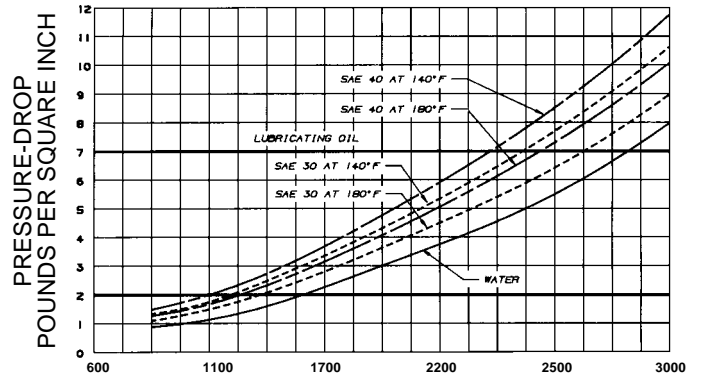

FLOW IN U.S. GALLONS PER MINUTE
Recommended pressure drop is 2 to 7 psi.

MODEL CODE SYSTEM

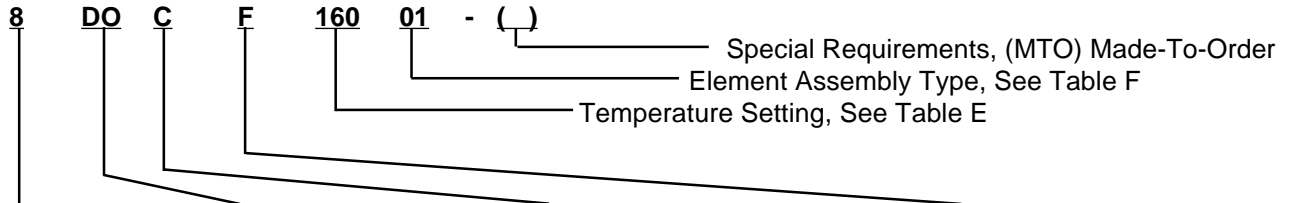

TABLE A Valve Size Inches (mm)	TABLE B Valve Type Code No.	TABLE C Body Material Code No. Material	TABLE D* Connections Code No. Type
8 (200)	DO Standard includes manual override	C Cast Iron (standard) S Steel B Bronze D Ductile Iron	F ANSI B16.1 (125 lb. Class) "FF Flange" J ANSI B16.5 (150 lb. Class) "RF Flange" G Undrilled Flange N Navy Flange per MIL-F-2004 (Special Order)
CONTACT FACTORY FOR OTHER FLANGES			

TABLE E Temperature Setting			TABLE F Element Assembly Type		
Code No.	Nominal Temp °F	(°C)	Code No.	Assembly Type	Type
080	80	(27)	01	5832X	Standard
097	97	(36)	02	5832P	Plated with Viton seals
110	110	(43)			
120	120	(49)			
130	130	(54)			
140	140	(60)			
150	150	(66)			
160	160	(71)			
165	165	(74)			
170	170	(77)			
175	175	(79)			
180	180	(82)			
190	190	(88)			
205	205	(96)			
230	230	(110)			

NOTE: Letters or numbers in the MTO space, other than nothing, A1 or AA, indicate the unit is built to special requirements and some of the other code numbers may not be valid. Check with the factory for full specification of such models.

* = Available from AMOT UK Only

Indicates Non-Standard, Special Charge

MAINTENANCE

Properly applied and installed, AMOT Thermostatic Valves require minimal maintenance. An inspection at 2 or 3 year intervals is adequate to detect and make provision for normal wear. A feature of Mode D Valves is that the element assembly may be removed from the valve for inspection or maintenance without removing the valve from the connecting piping.

Remove Cover (20) and the sliding valve assembly by removing ten Capscrews (38). Eye Bolts (42) can be used as jack screws to break the seal. Sliding Valve (48) should be in the position shown on the assembly drawing with Port C in the fully closed position. If not, break Wire Seal (32), remove Cap (33), loosen Nut (34) and with a wrench turn the flat end of Pushrod (50) clockwise moving Sliding Valve (48) to the closed position. Remove Ring (23) and Plug (57) from Element Tube (55). Temperature Elements (56) and Guide (54) are then removed from the Element Tube. On reassembling, use reverse procedure, making sure that Temperature Elements and the Guide are correctly inserted into the Element Tube. New Temperature Elements are factory-calibrated for exact replacement without setting on the job.

SERVICE PARTS

Ref No.	Part No.	Qty	Description
5	556	1	O-ring, Element Assem, Buna N
6	5849	1	Gasket, Housing
25	1919	1	O-ring
41	707	1	O-ring
56	5832X (temp)	4*	Temperature Element, Standard, specify temperature in °F.
56	5832P (temp)	4*	Temperature Element, Plated, specify temperature in °F.

This Parts List effective with Valve Serial No. C641.

* All 4 must be replaced. Do not use old ones with new.

When communicating with AMOT regarding operation of a control, always give the Model No. and Serial No. If ordering service parts, also include the Description, Part No., and quantity desired. If any parts are ordered by Reference No. only, please also include the Form No., Revision No., and date of this brochure.

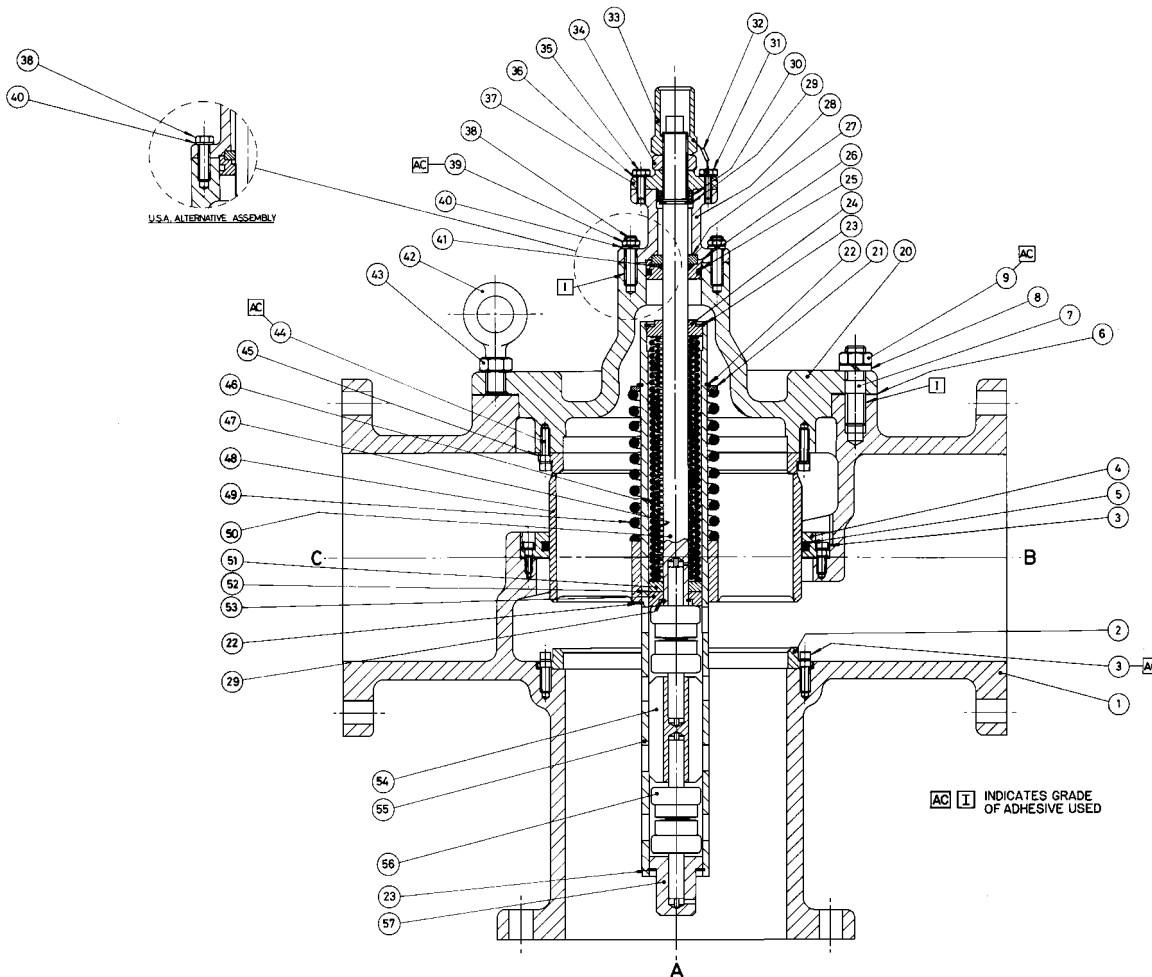

AMOT Controls Corporation
 401 First Street
 Richmond, CA 94801-2906
 Tel: (510) 236-8300
 Fax: (510) 234-9950

AMOT Controls Ltd.
 Western Way
 Bury St. Edmunds IP33 3SZ
 Suffolk England
 Tel: (284) 762-222
 Fax: (284) 760-256

AMOT Controls Corporation
 230 Orchard Road
 # 09-230 Faber House
 Singapore 0923
 Tel: (65) 235-8187
 Fax: (65) 235-8869